

wood luck

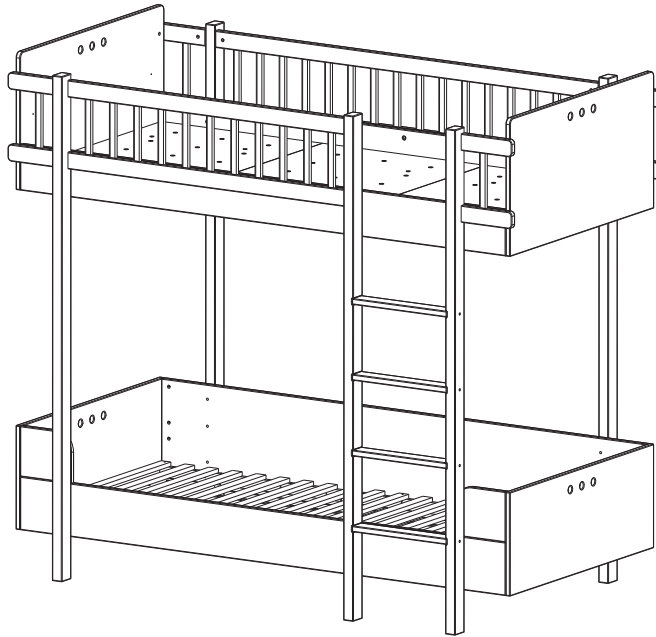

Basic

Bunk Bed/ Łóżko piętrowe



1850mm x 2076mm x 1056mm

GLUE x1	o2 x4	o5 x2	k8 x58	
a12 x74	a11 Ø 10x13 x74	a13 x74	a3 Ø 15x12 x8	a4 L-84 x4
h6 Ø 6x30 x49	f1 Ø 6x20 x32	c6 Ø 4x25 x32	h9 Ø 10x13 x8	x1 x1
c7 Ø 4x40 x10	f5 Ø 8x32 x48	h5 Ø 6x70 x8	x3 x1	

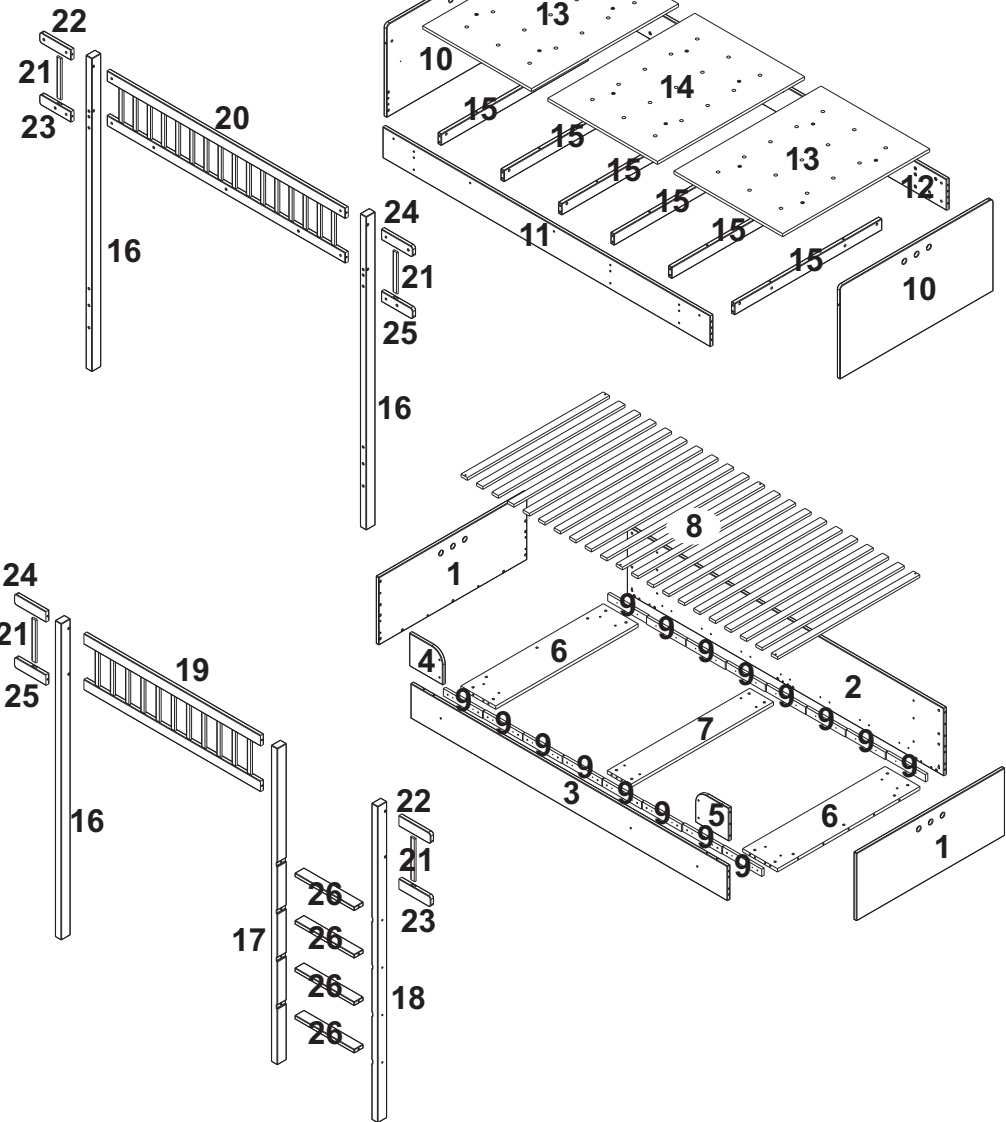
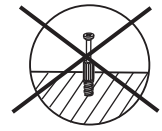
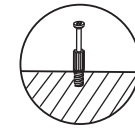
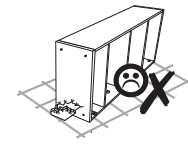
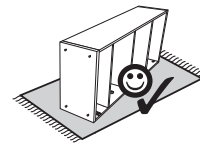

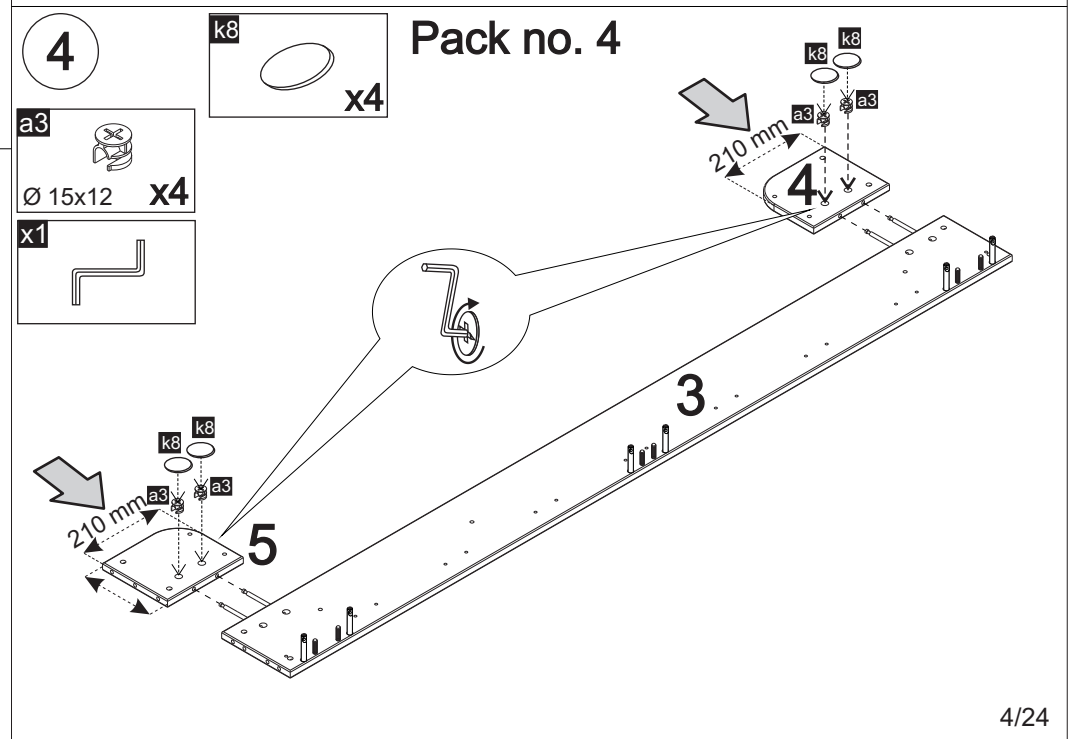
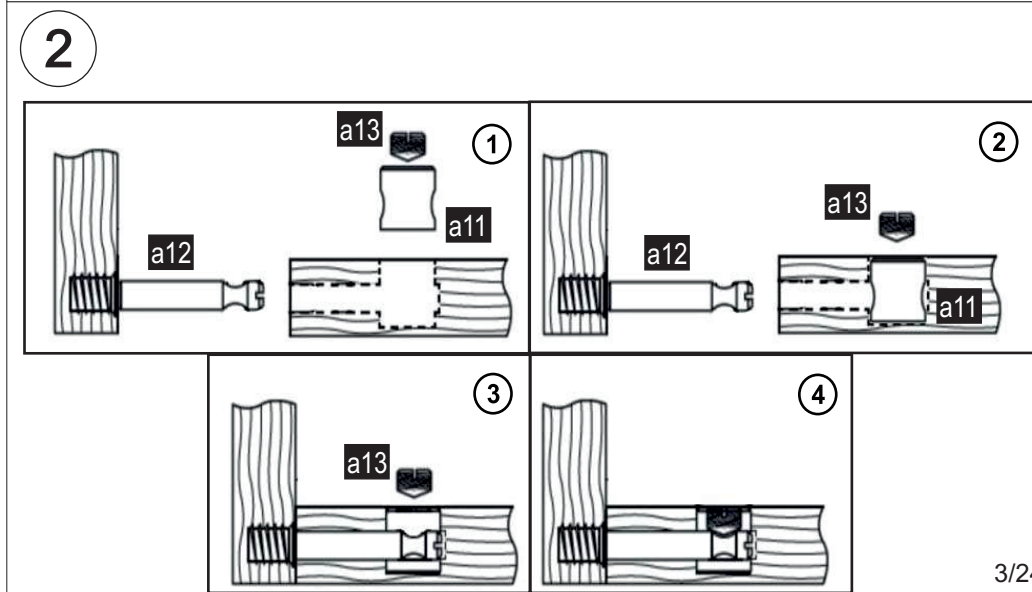
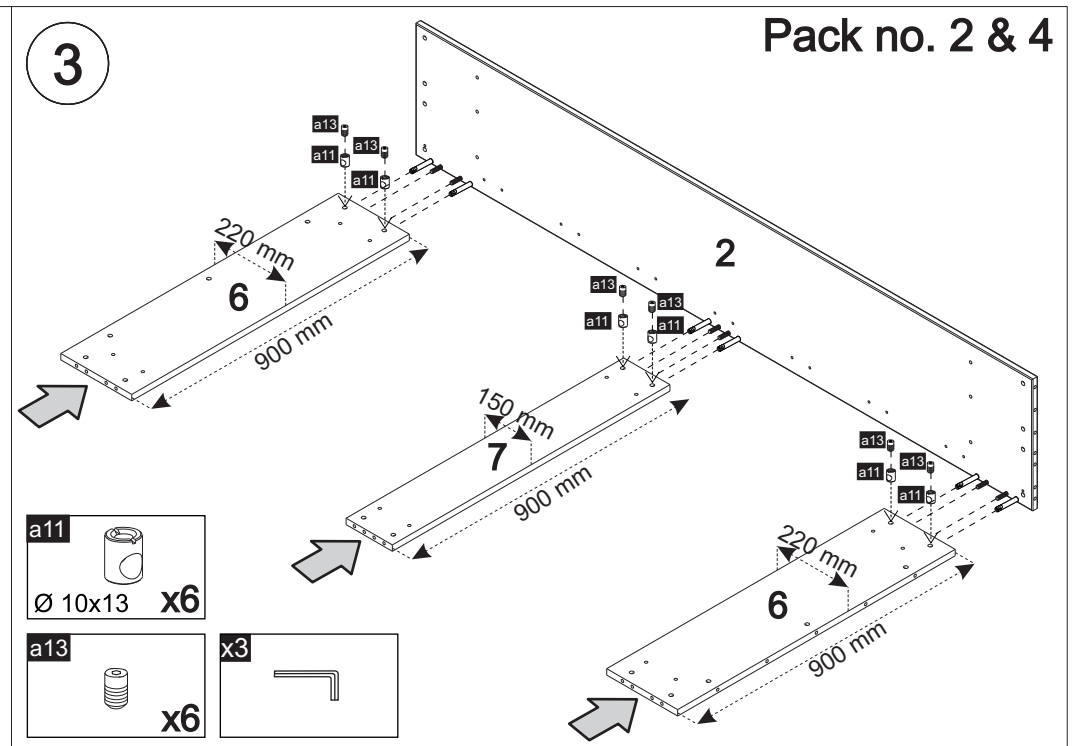
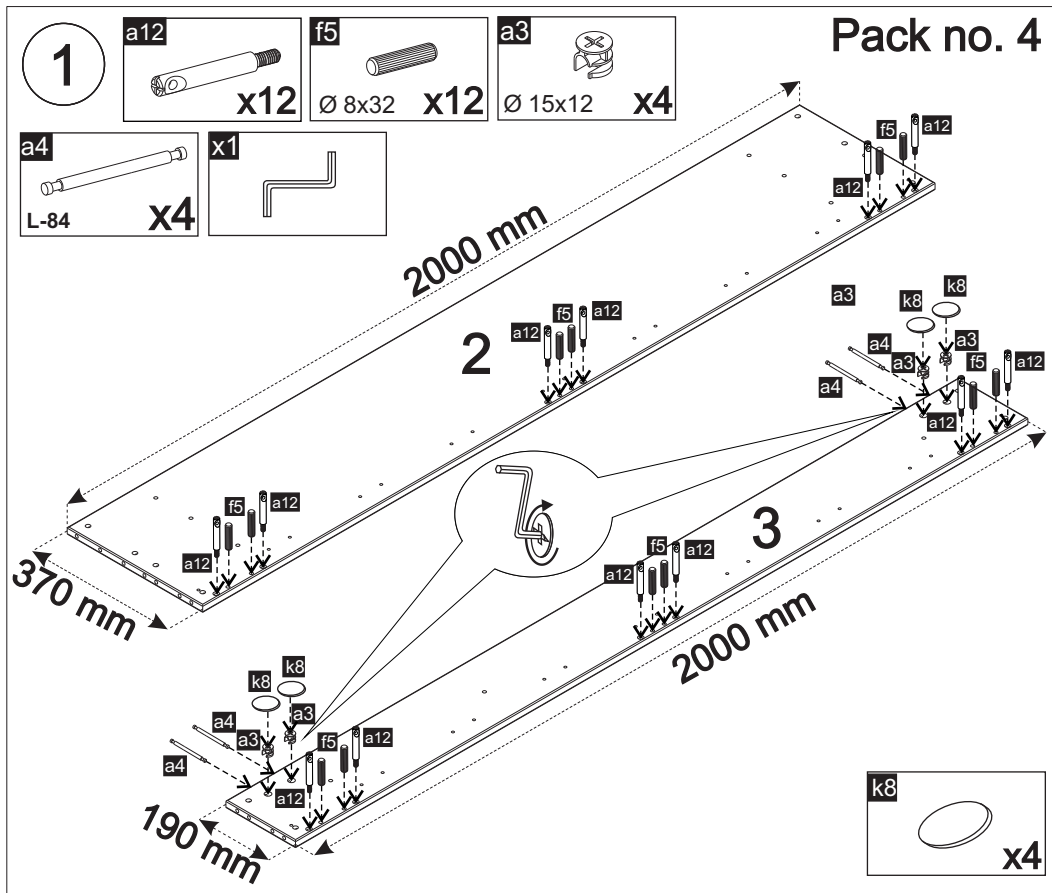

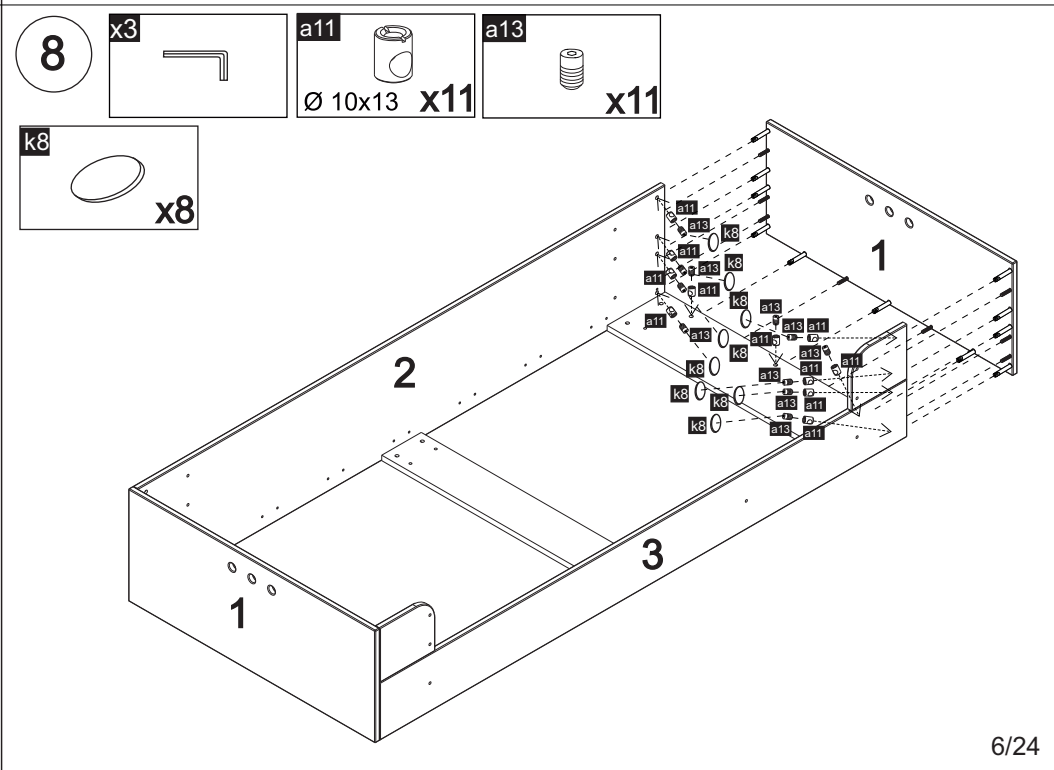
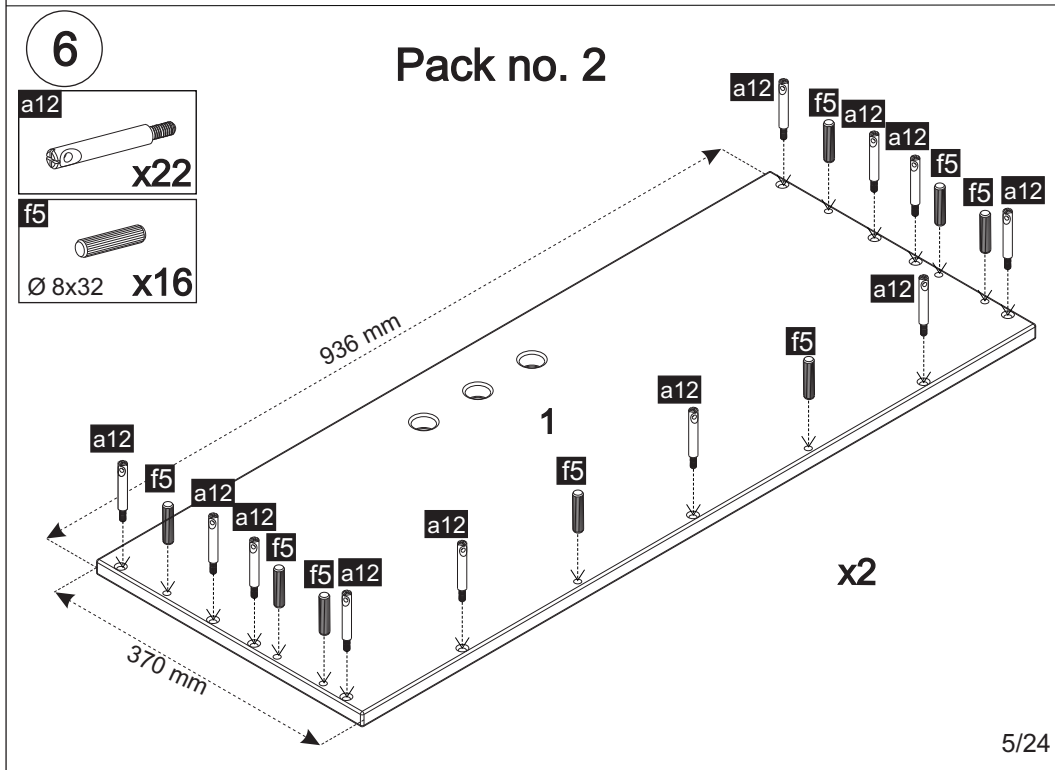
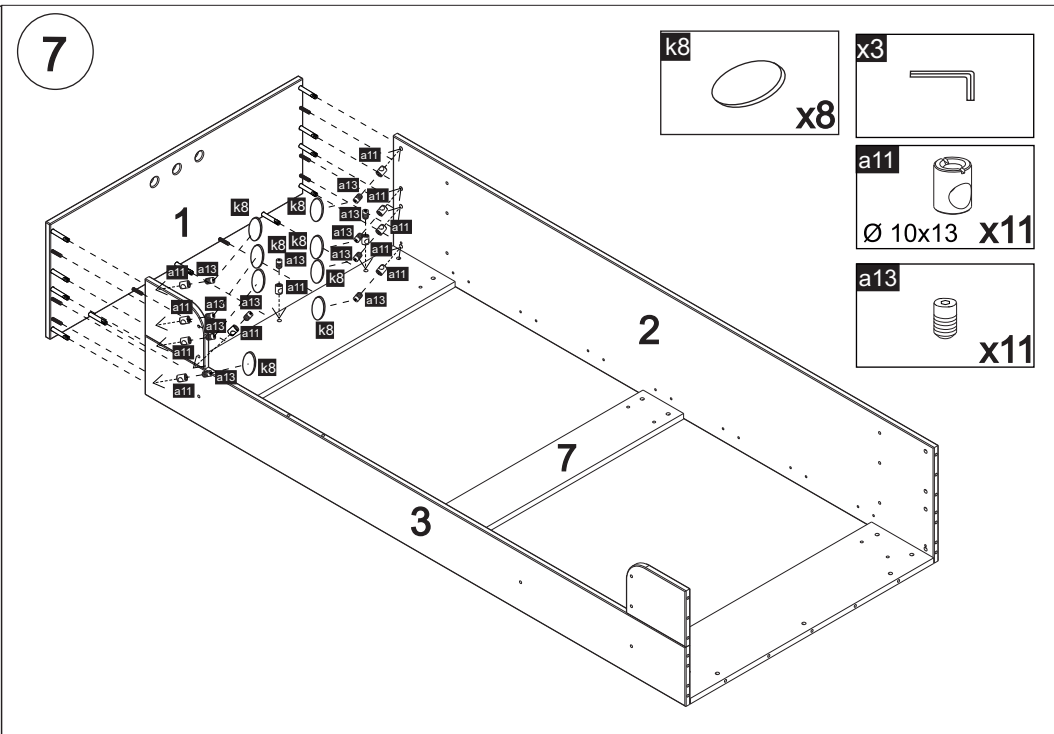
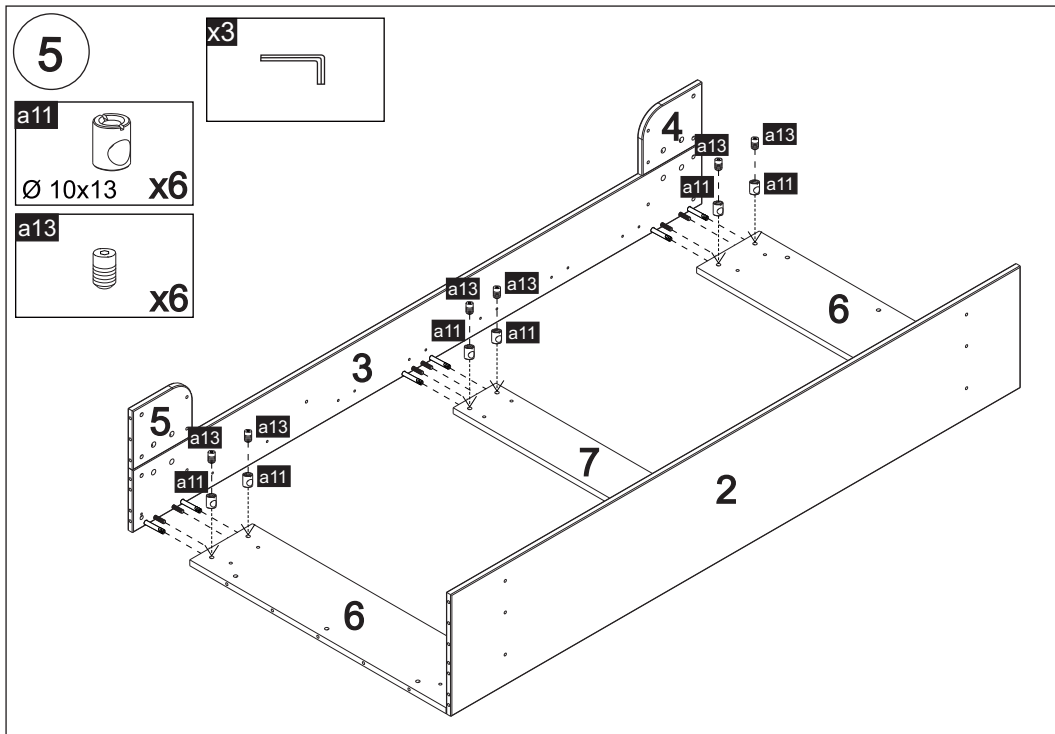

9

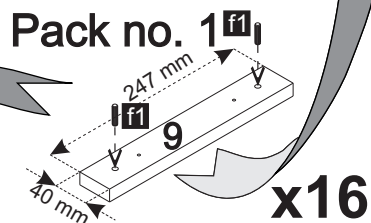
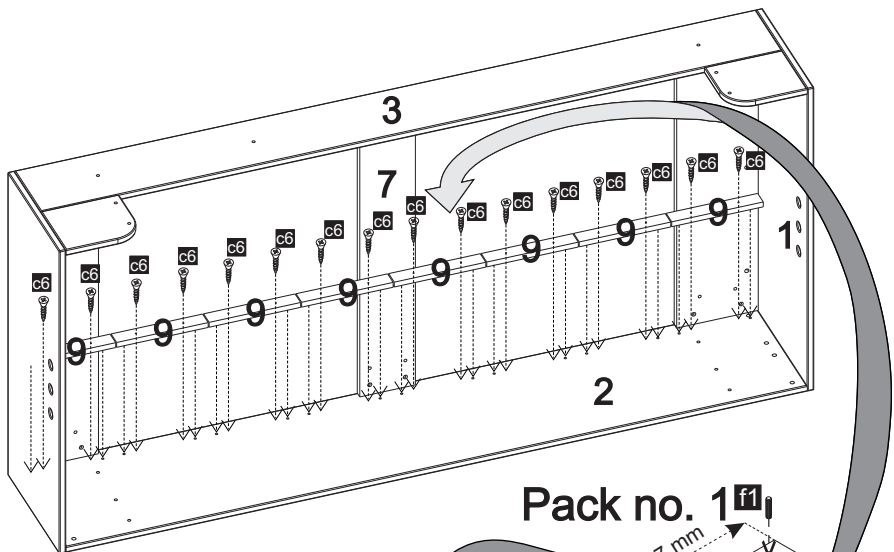
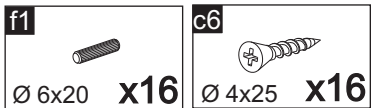

10

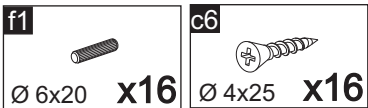
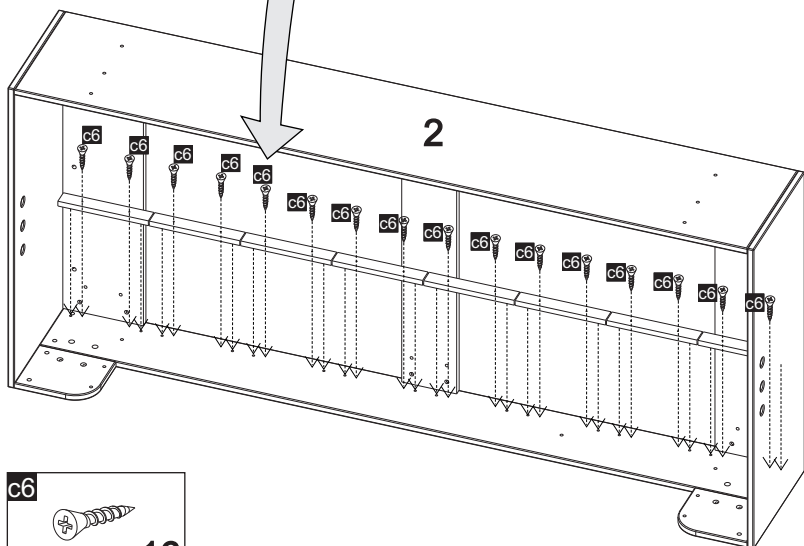

11

Pack no. 4

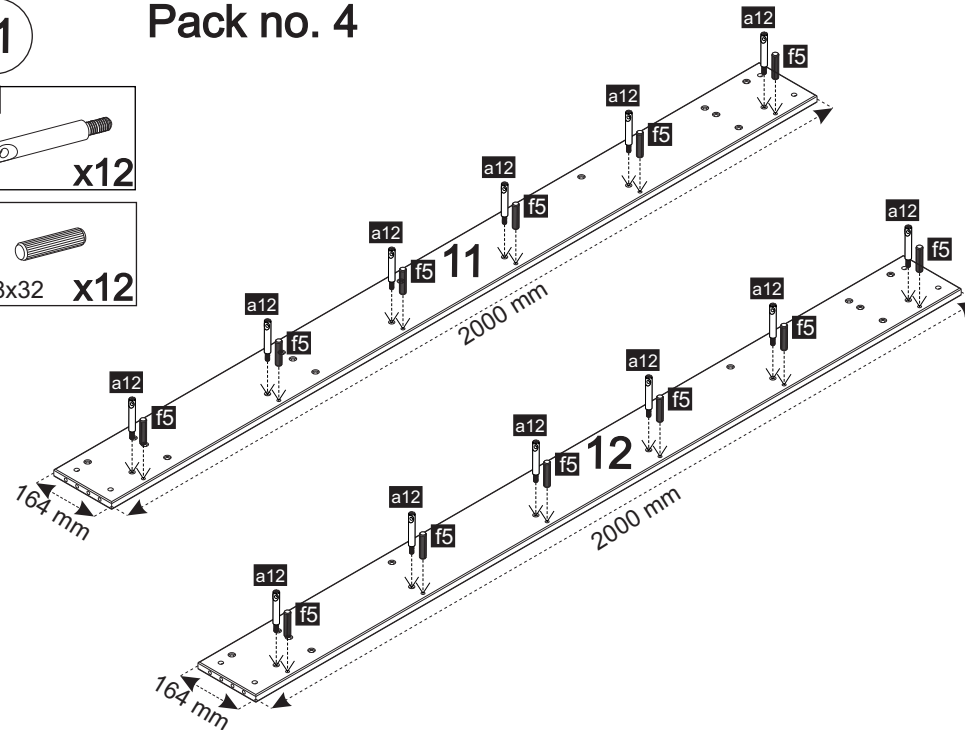
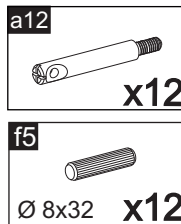

12



Pack no. 3

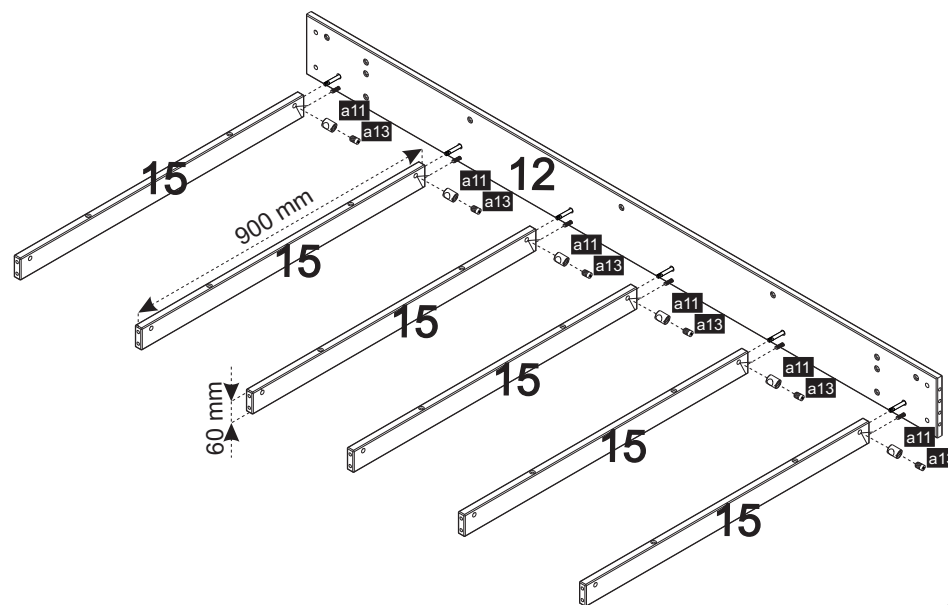

13

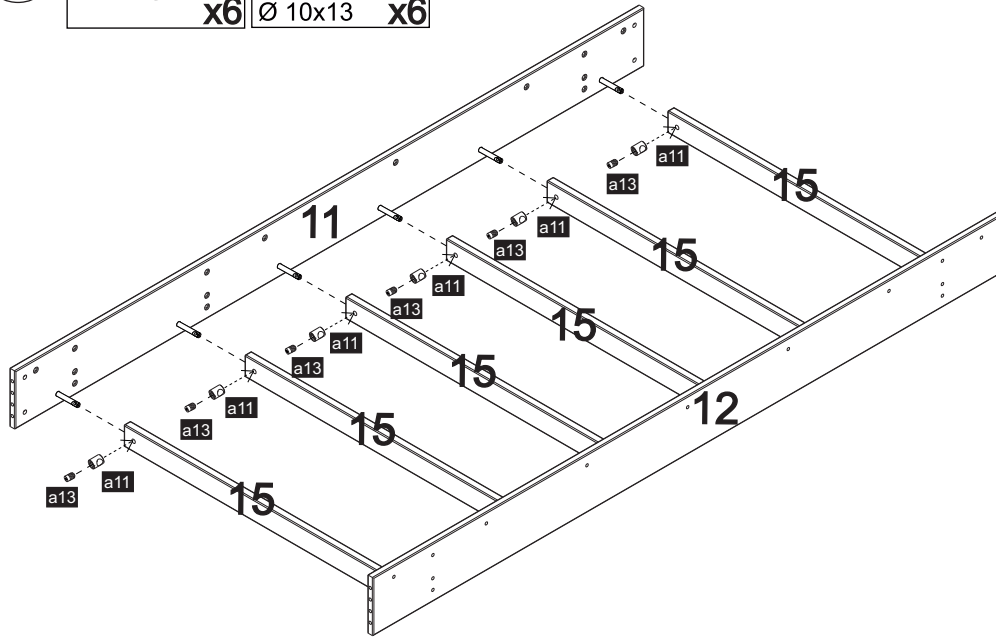

15

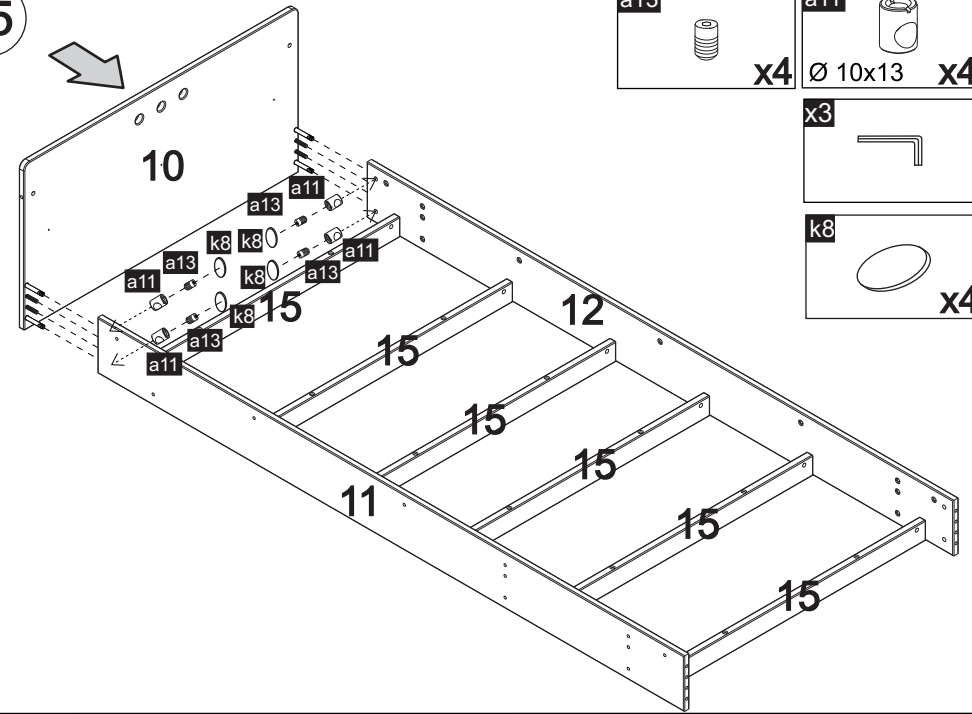
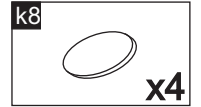
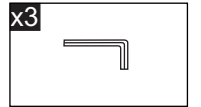
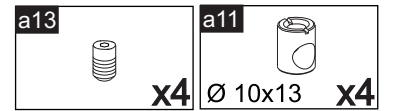

14

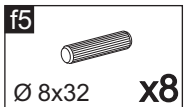
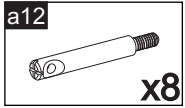

maksymalna rekomendowana wysokość górnej płaszczyzny materaca w górnym łóżku// maximum recommended upper surface of the mattress in higher bed



IMPORTANT! / WAŻNE!

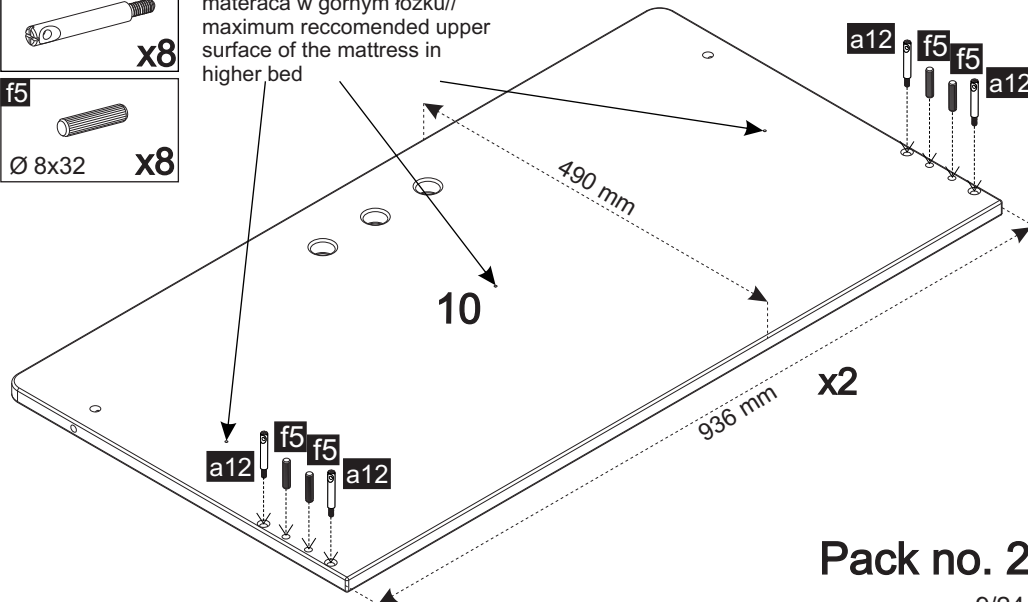

16

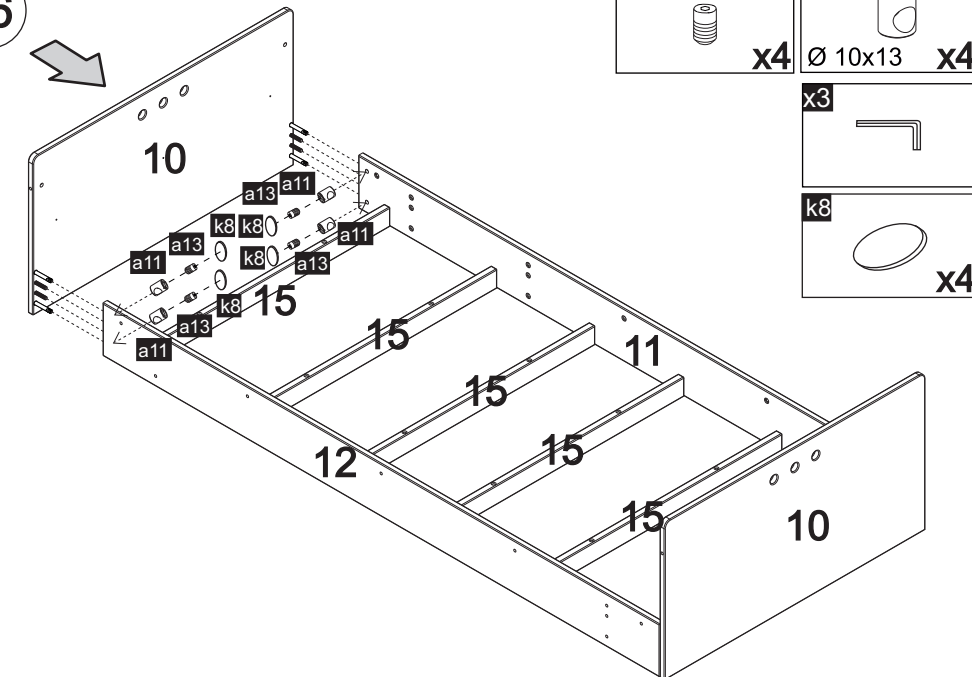
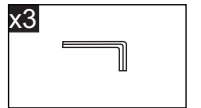
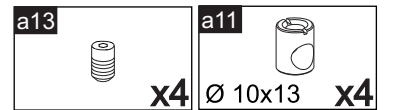

Pack no. 2

17

Pack no. 3

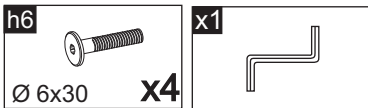
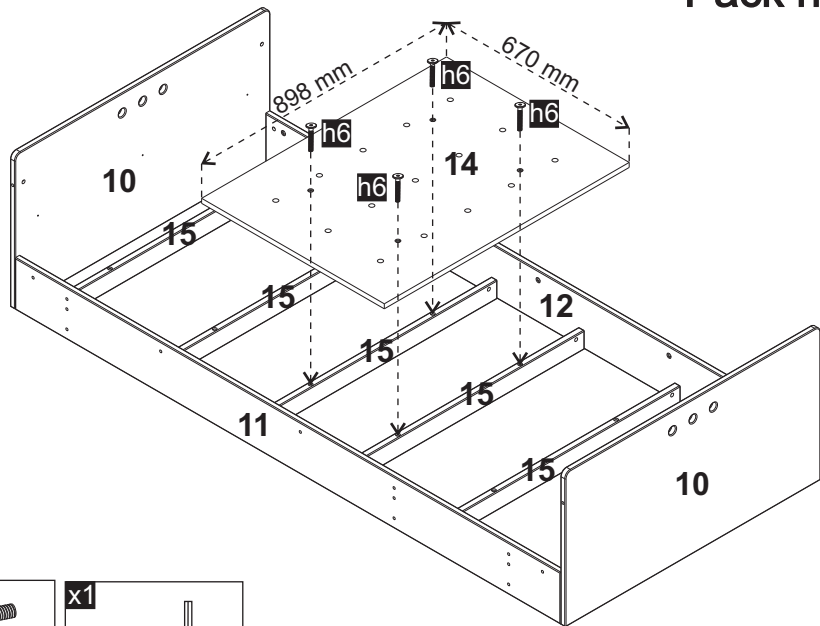

19

Pack no. 5

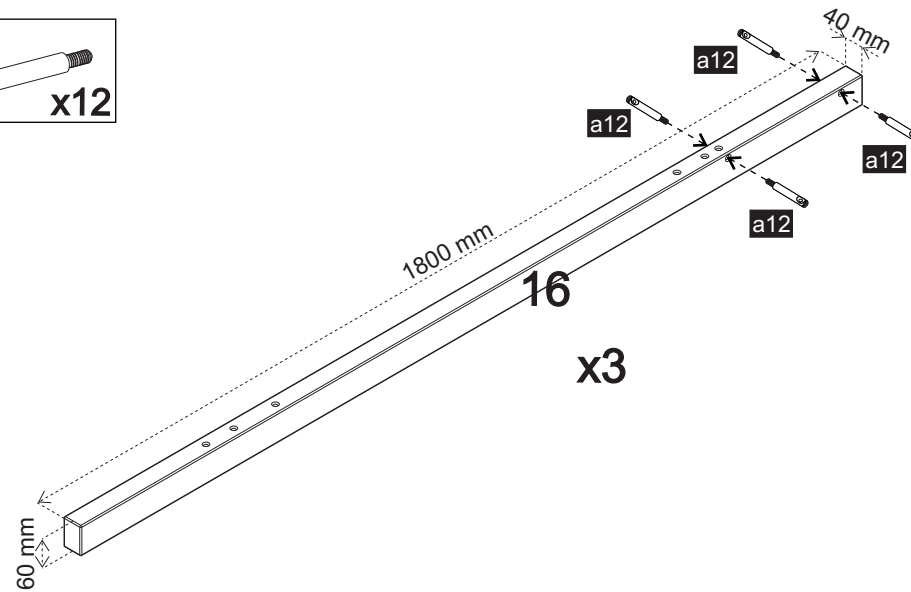
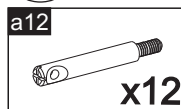

18

Pack no. 3

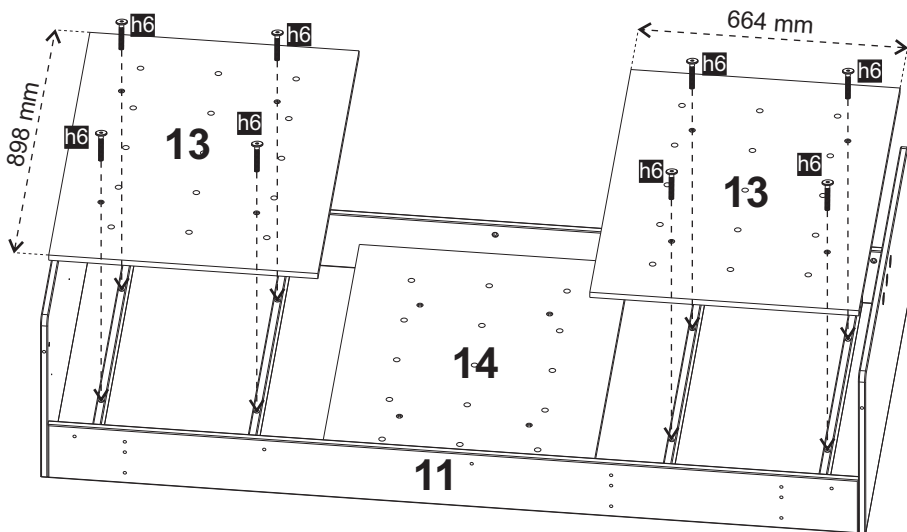
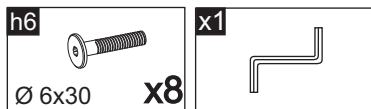

20

Pack no. 5

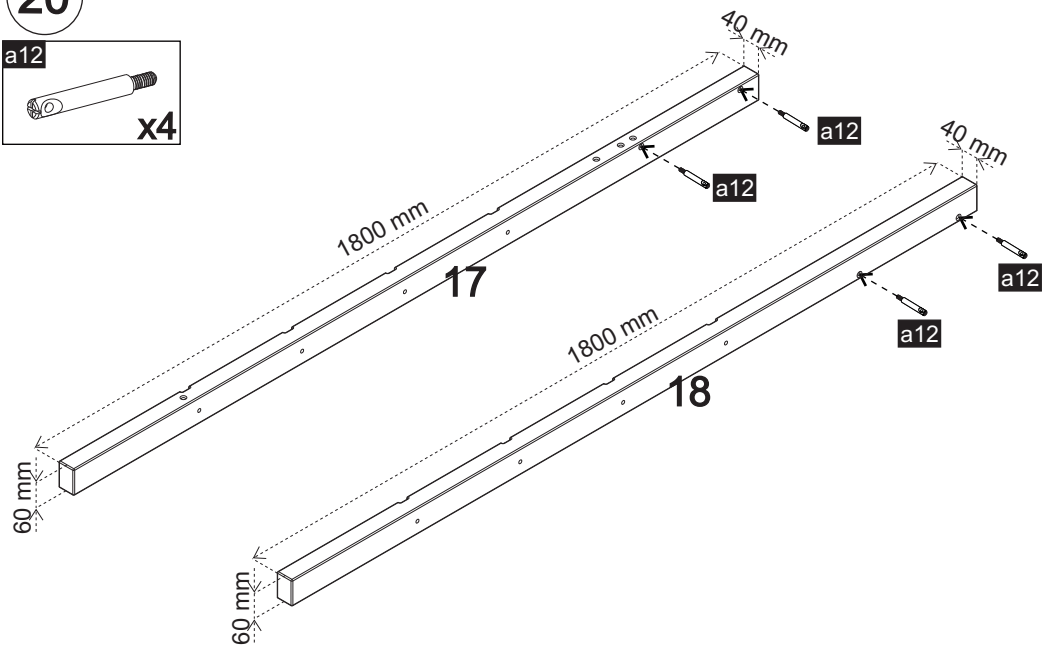
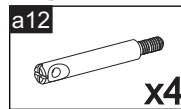

21 x2

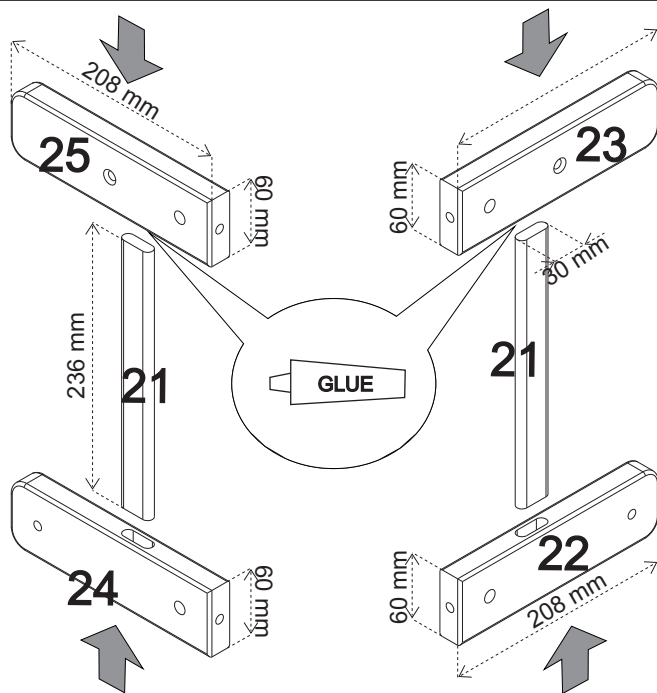

Pack no. 1

23

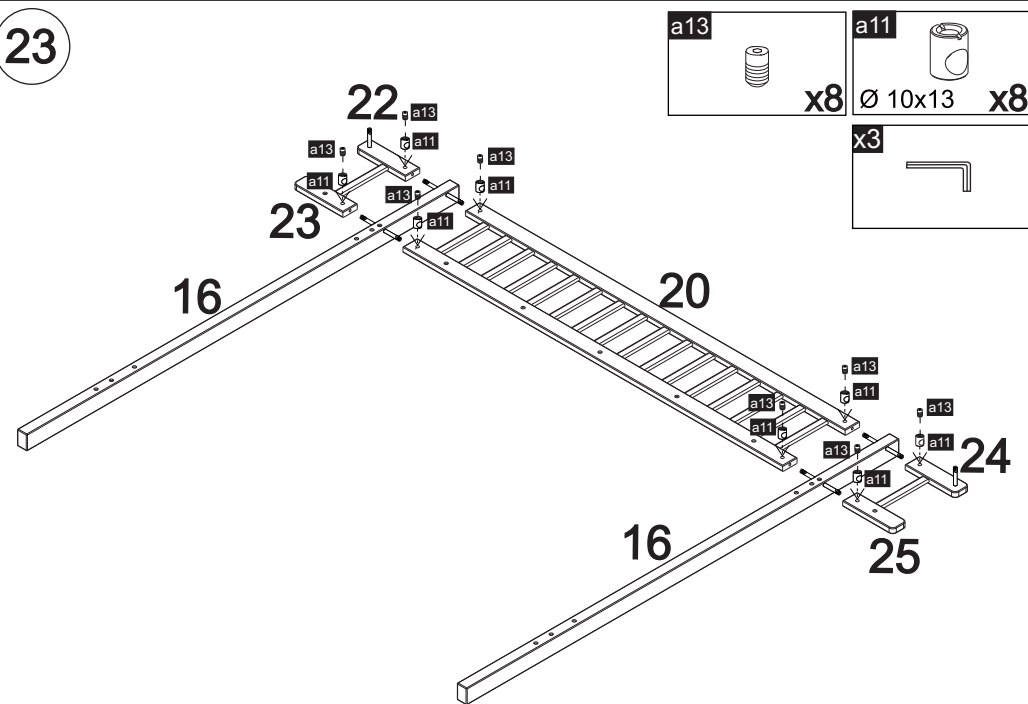

22

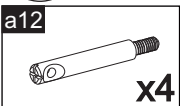

IMPORTANT! / WAŻNE!

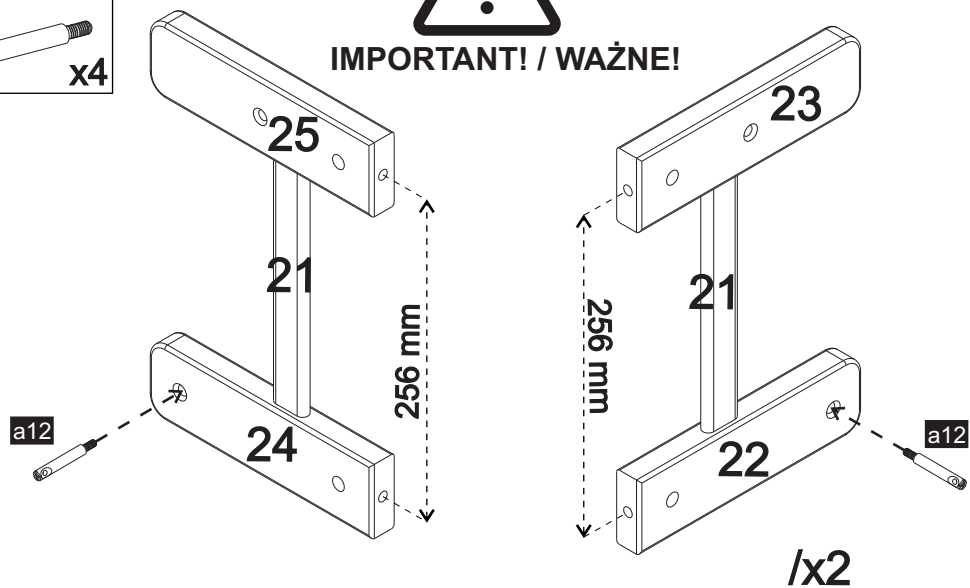

13/24

24

Pack no. 1

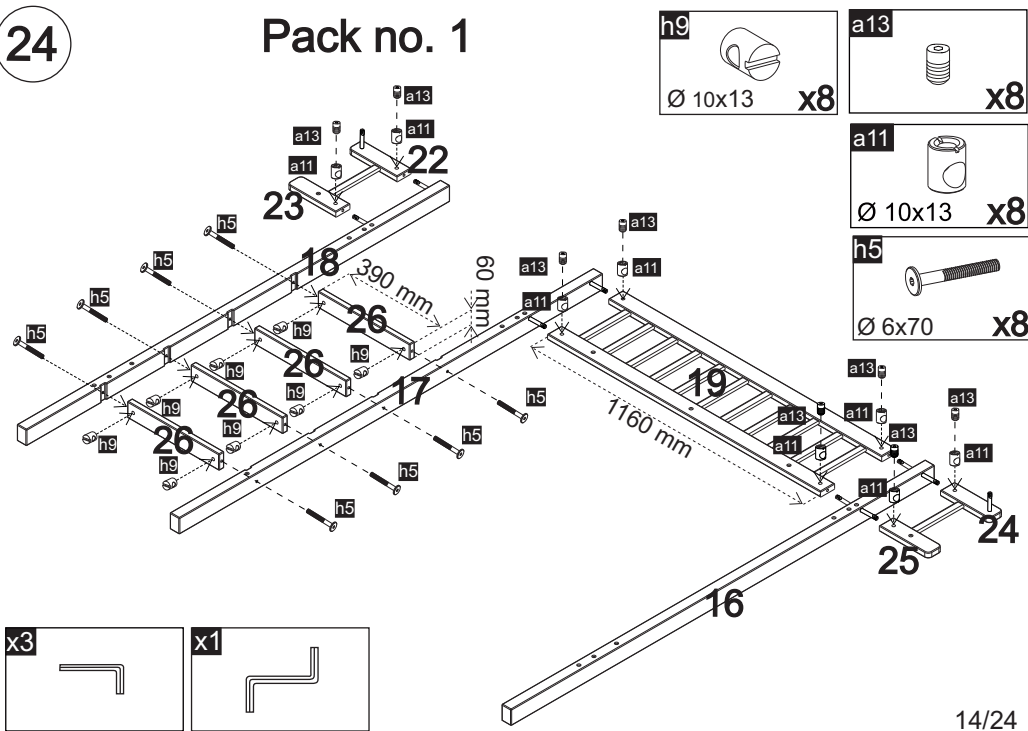

14/24

25

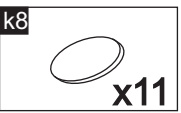
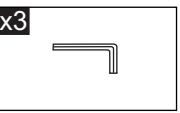
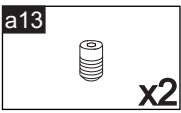
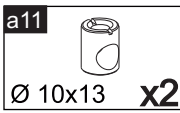
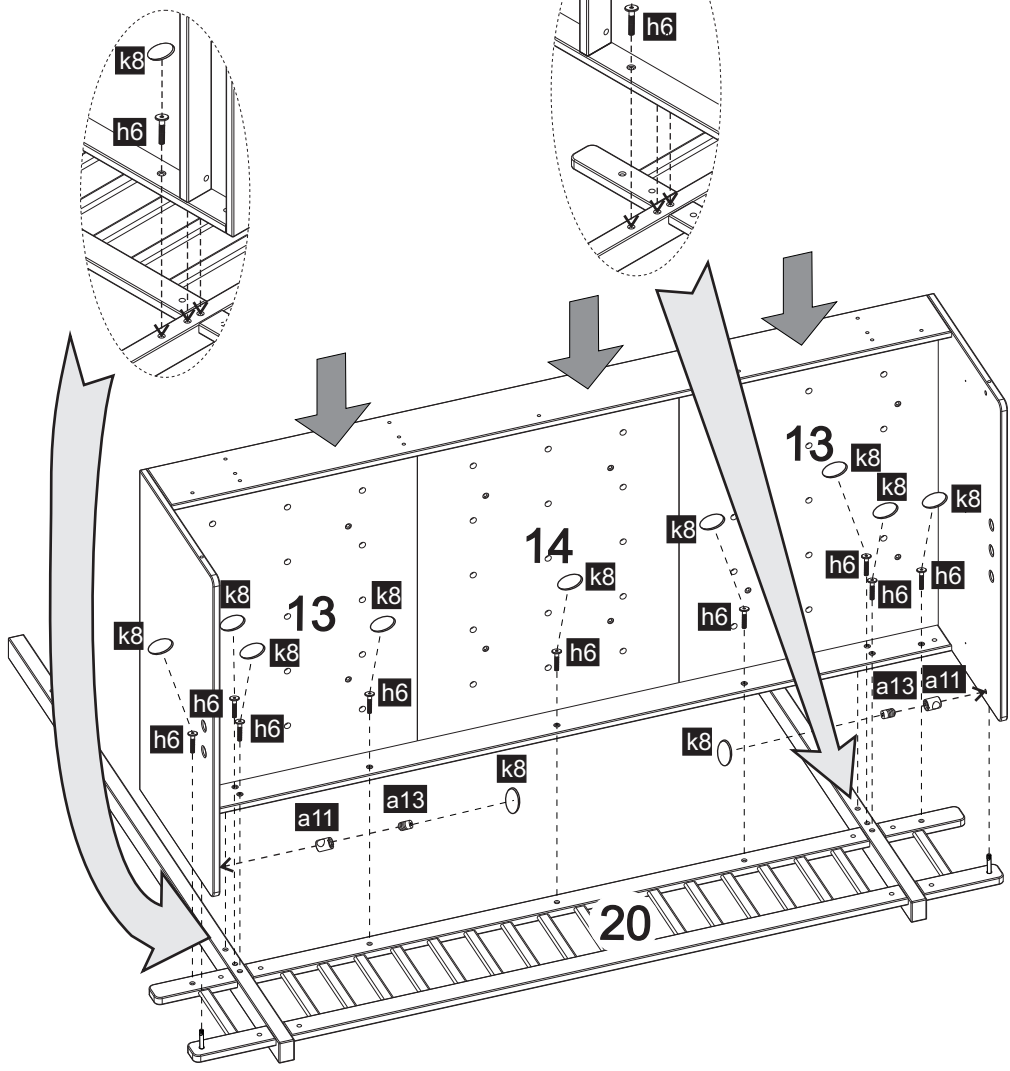
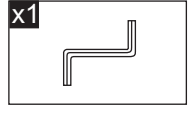
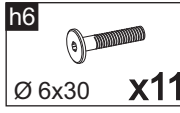

26

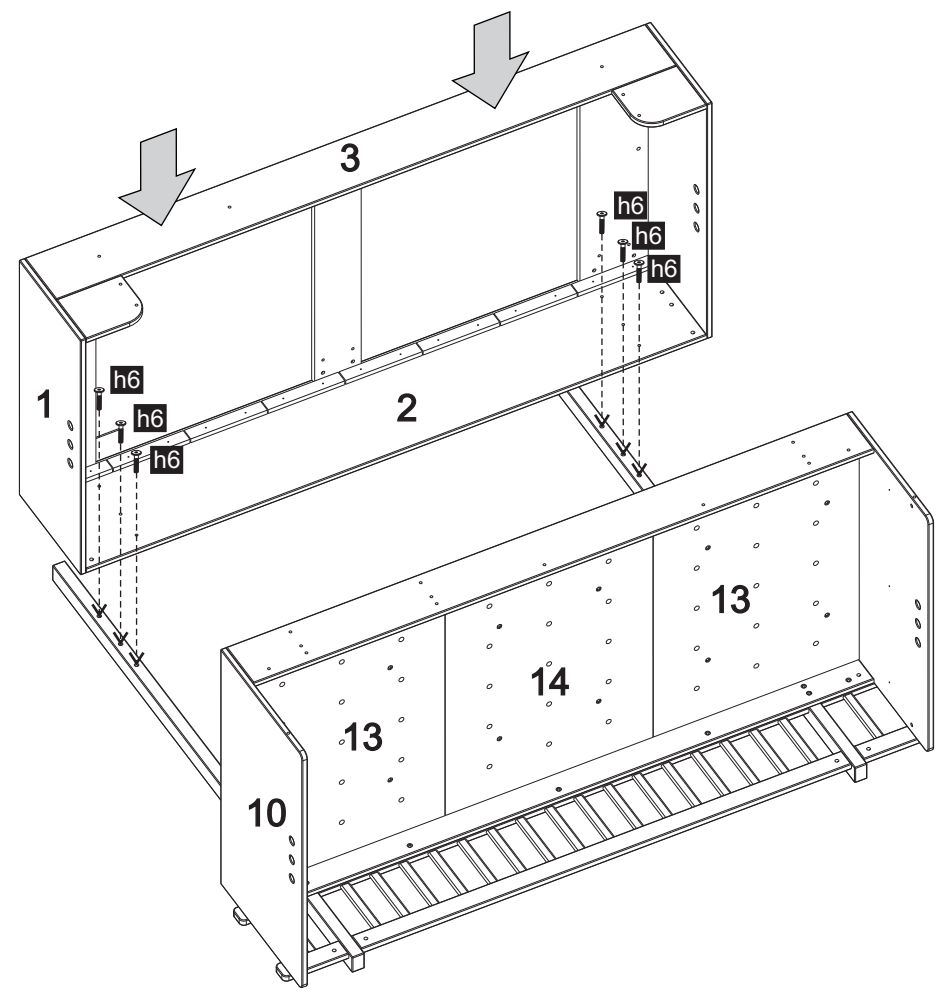
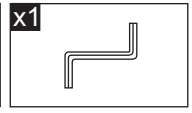
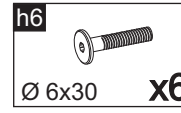

27

h6
Ø 6x30 **x20**

x1

a11
Ø 10x13 **x2**

a13
x2

x3

k8
x15

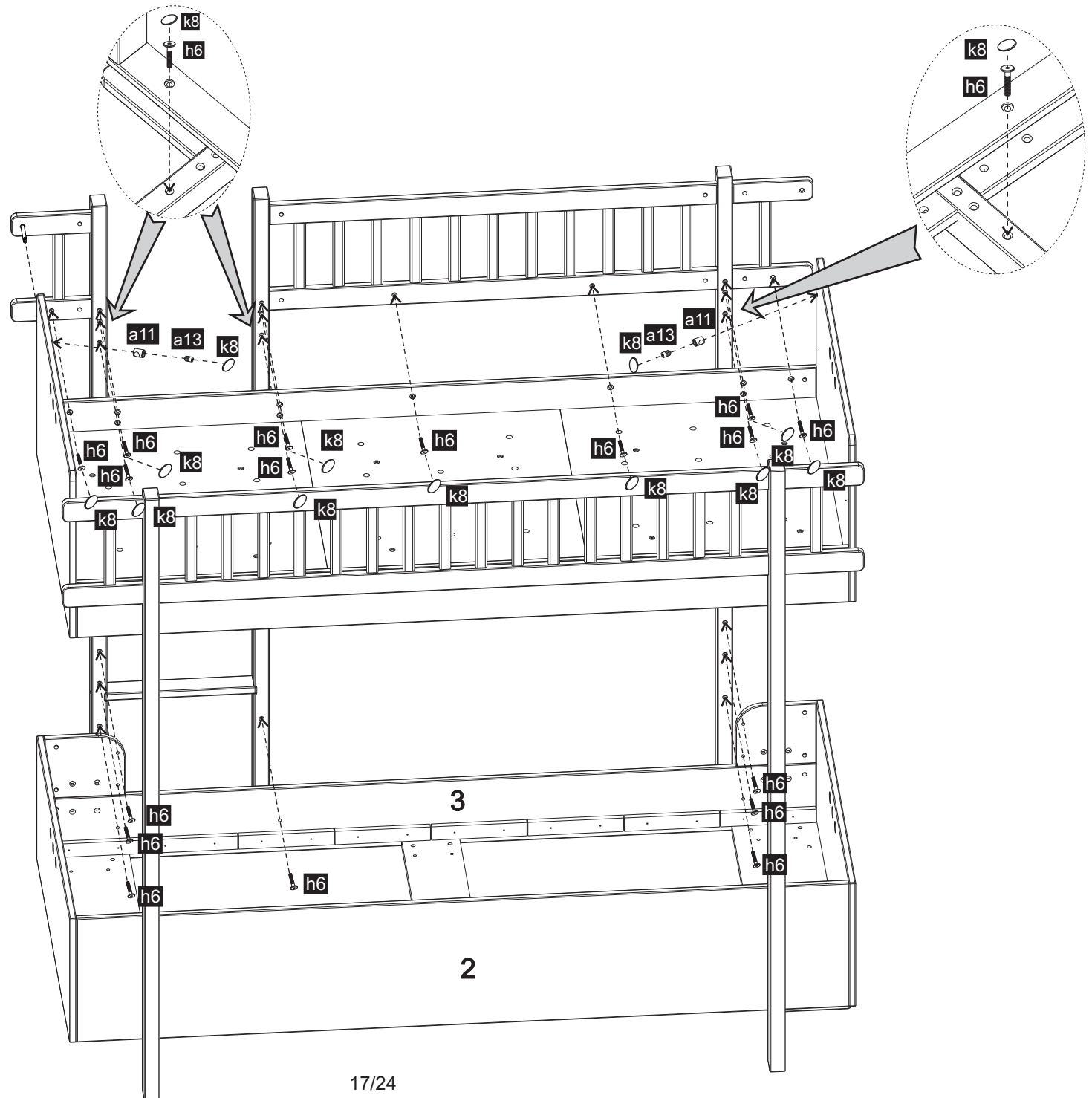

28

Pack no. 3

c7



Ø 4x40 x6

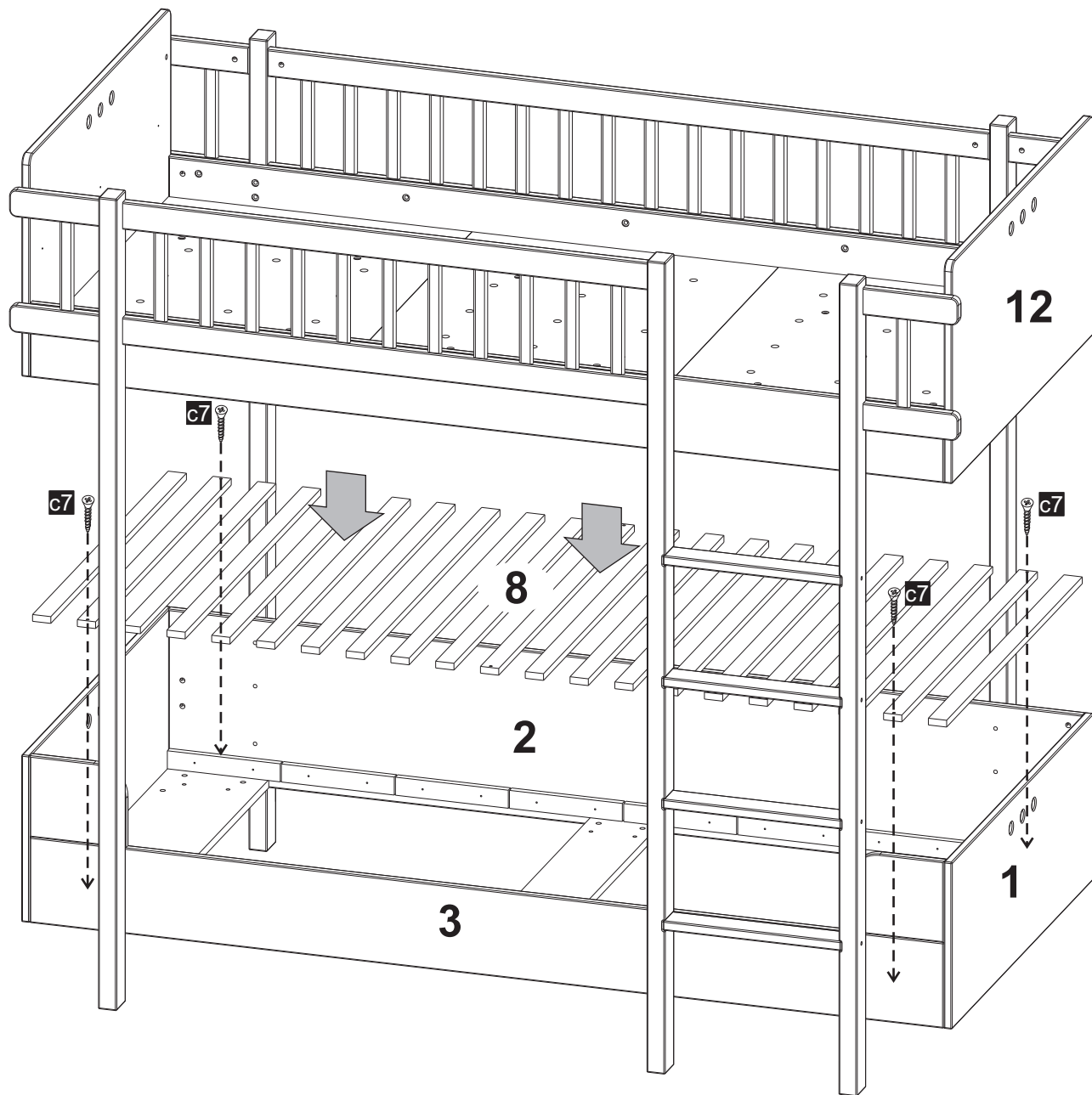

29

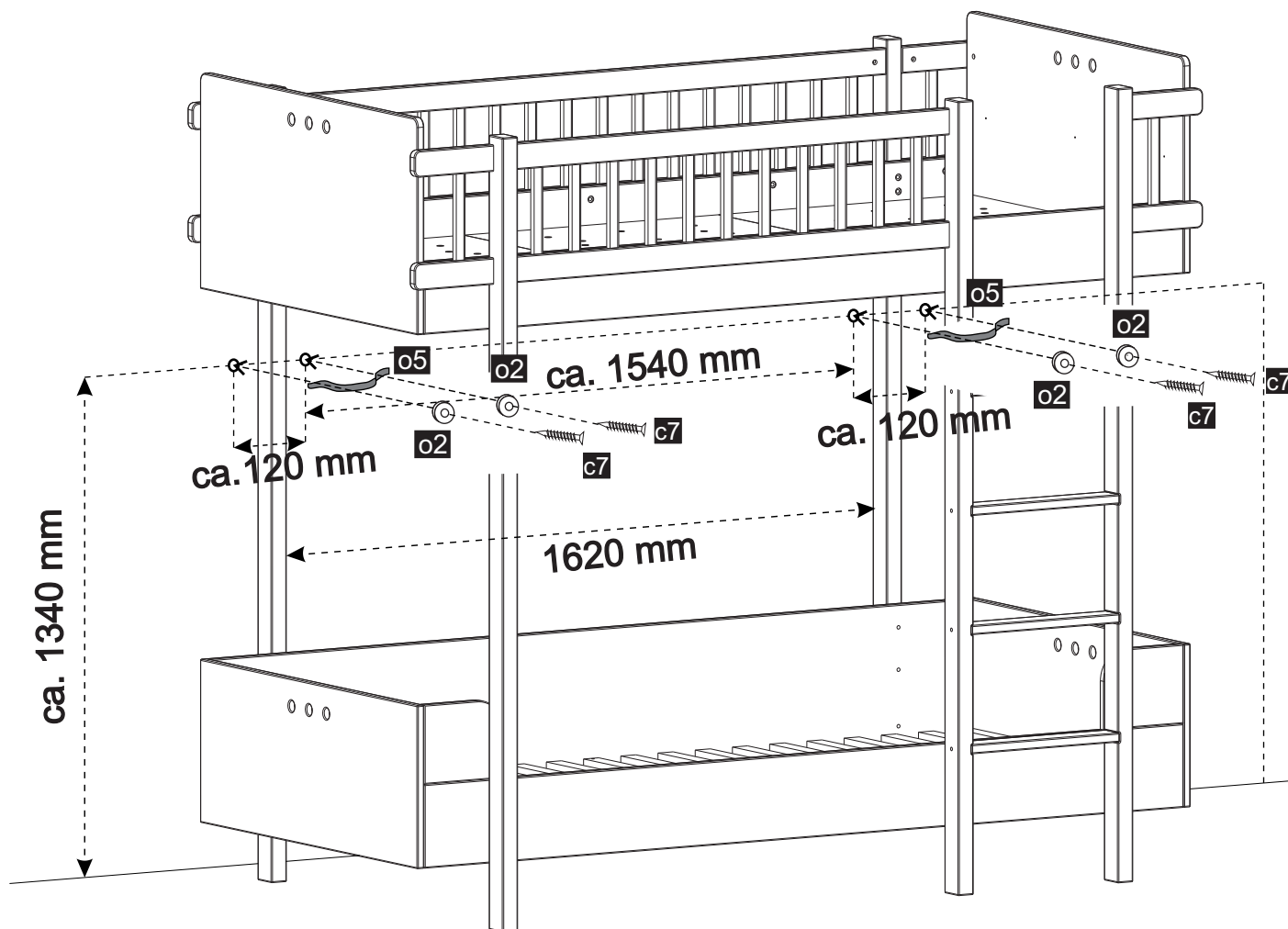
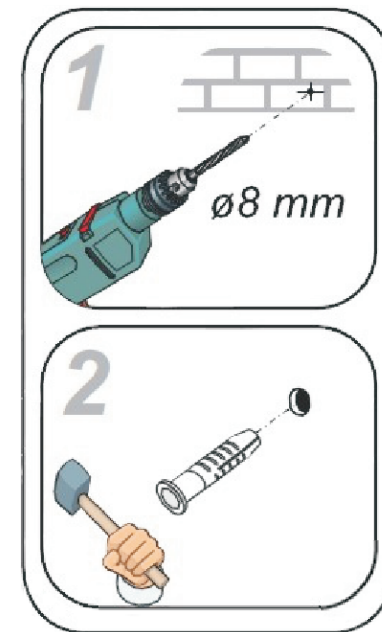
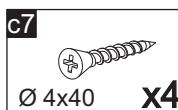
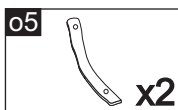
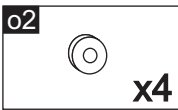



“WAŻNE! - UWAGNIE PRZECZYTAĆ ZACHOWAĆ DO PÓŹNIEJSZEGO STOSOWANIA”

PL

1. To górne łóżko jest nieodpowiednie do stosowania przez dzieci poniżej 6 roku życia
2. Wysokość materaca w górnym łóżku nie powinna przekraczać 180mm.
3. Nie używać łóżka gdy jakaś jego część jest uszkodzona lub jej brakuje.
4. Należy stosować tylko części zamienne zatwierdzone przez producenta.
5. Ostrzeżenie! Nie używać w łóżku więcej niż jednego materaca.
6. Wszystkie okucia powinny być dobrze dokręcone, tak aby uniemożliwić zahaczenie się ciała lub elementu odzieży dziecka (np. sznurki, naszyjniki lub tasiemki od smoczków), co mogłoby spowodować niebezpieczeństwo uduszenia.
7. W trakcie użytkowania łóżka należy okresowo sprawdzać, czy nie nastąpiło poluzowanie połączeń śrubowych. Jeżeli tak, śruby należy dokręcić do wystąpienia oporu.
8. Podczas przebywania w górnym łóżku nie należy po nim skakać!
9. Przytwierdzenie łóżka piętrowego do ściany jest niezbędne celem zapewnienia stabilności podczas jego użytkowania!

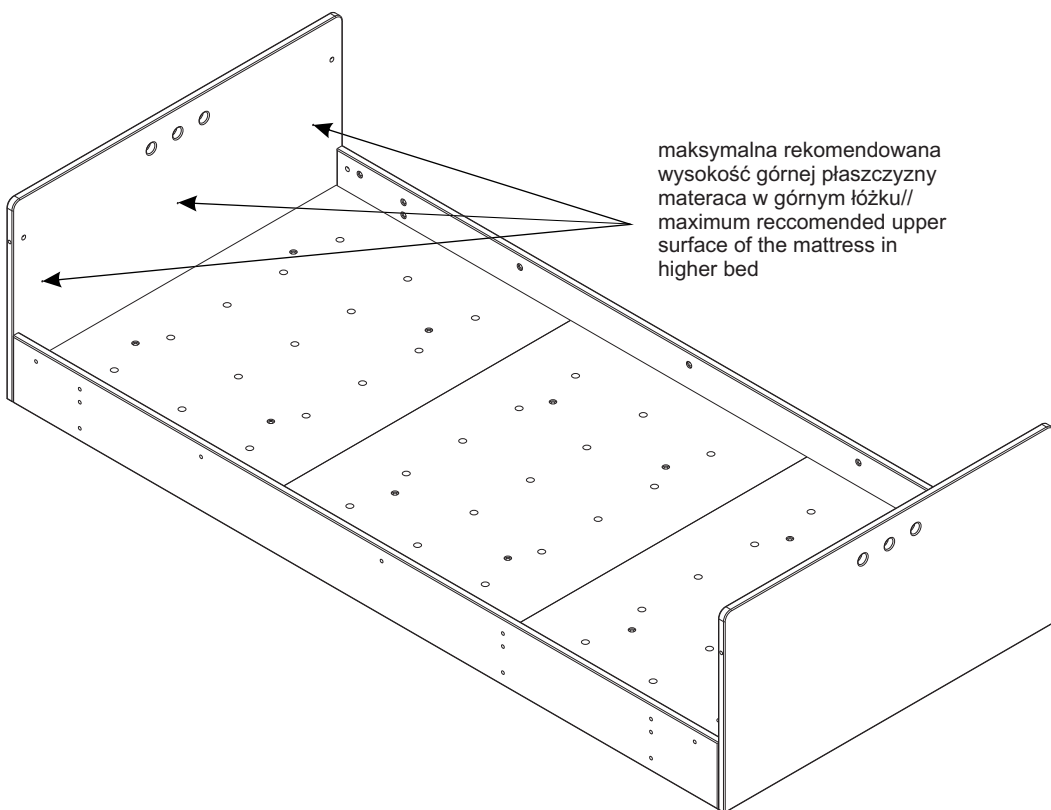

EN

“IMPORTANT, READ CAREFULLY RETAIN FOR FUTURE REFERENCE”

1. This upper bed is not suitable for children under six years.
2. The mattress in upper bed should not be thicker than 180 mm.
3. Do not use the bed if any part is broken, torn or missing.
4. Should use only spare parts approved by the manufacturer.
5. Warning! Do not use more than one mattress in the bed.
6. All assembly fittings should be tightened properly and care should be taken to ensure that no screws are loose, a child could trap parts of the body, or clothing (e.g. ribbons, drawstrings, necklaces) this could pose a risk of strangulation.
7. Regularly check that all fittings and components of the bed are fully tightened and in working order.
8. Do not jump in the high bed while being in the high bed!
9. Fastening the bunk bed to the wall is necessary to ensure stability during use!